

Single fulcrum hinge

For door weights up to 12Kg

Applications

✓
Dishwashers

Geometry

✓
Footprint: W, H, L
Fulcrum position (respect to the base): X, Y

Technical features

✓
Fulcrum position (respect to the upper fixing point) X=32mm
Y=184mm
Footprint: W=158mm, H=34mm, L=384mm
Type of fixing: four frontal holes to fix the hinge to the dishwasher, one of which in M5 and two holes between the hinge and the door.

Functionality

✓
Balancing: 0 - 87°
Automatic door opening function: available on customer request
Closing forces: 5 - 10N depending on the weight of the door
Pre-load position: available at 27°

Removability

✓
Through two M5 screws

Performance

✓
Resistance to static load: till 25Kg
Dynamic test: till 25k cycles

Compliance

✓
Hinge complies with VDE anti-crushing regulations

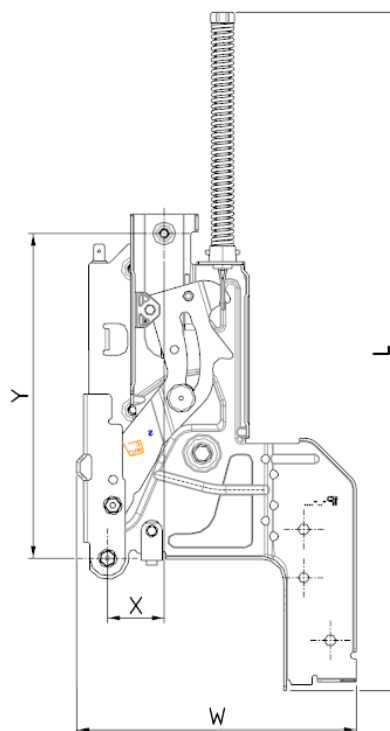
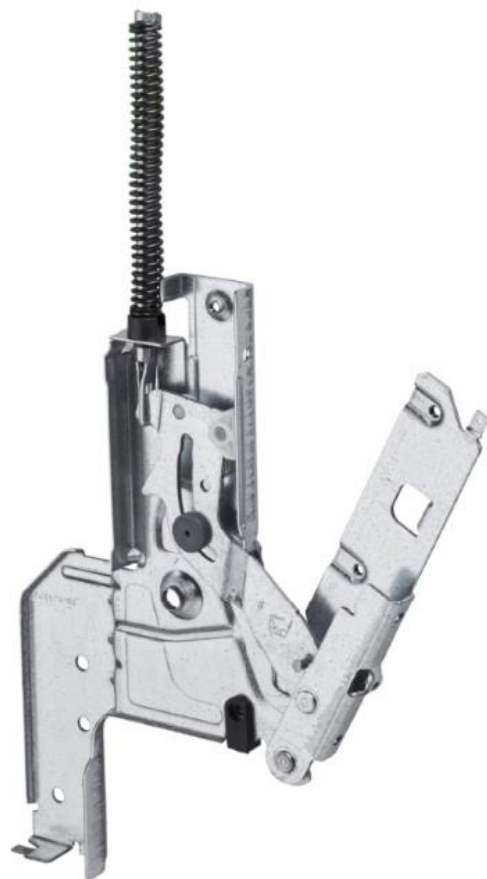

2D Drawing

The following drawing shows the main functional dimensions.
Possibility of customized designs based on customer needs

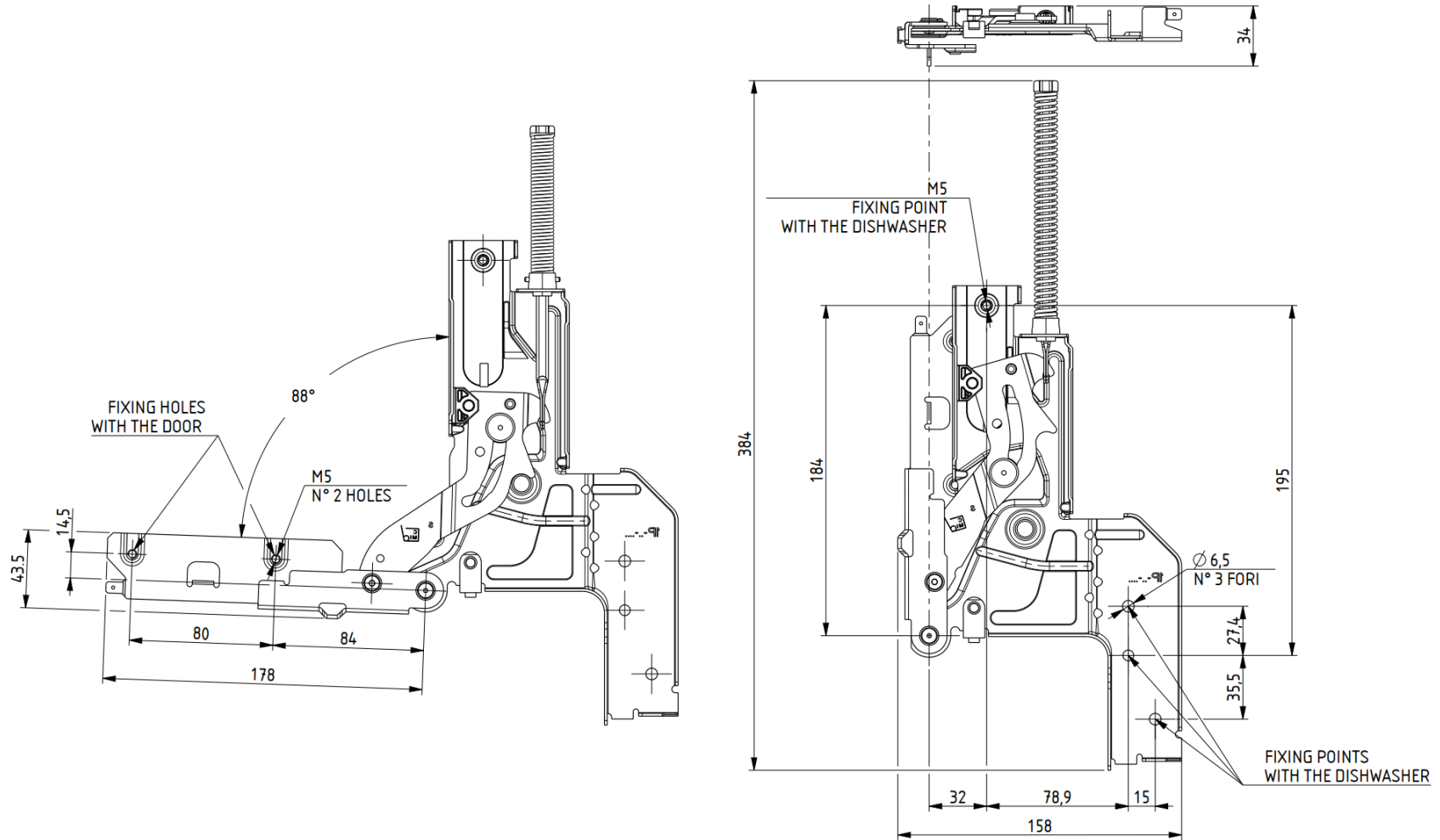

C.M.I. Cerniere Meccaniche Industriali s.r.l.

Via 2 Agosto 1980, 1/D, Località Crespellano - 40053 Valsamoggia (BO), Italia

Tel. +39 051 6713411 - Fax +39 051 969940 - www.cmi-hinges.com

Capitale sociale i.v. Euro 1.000.000 - Registro imprese di Bologna: 50450 - N.REA: BO 318209